



Advantages:

- ✓ High force generation
- ✓ Compact design
- ✓ Adjustable clamping point
- ✓ Lever Ratio 1:1 with Standard-Clamp arm
- ✓ No interference contour = completely free loading
- ✓ Insensitive to hot chips
- ✓ With optional pneumatic detection
- ✓ Lateral force optimized



Description

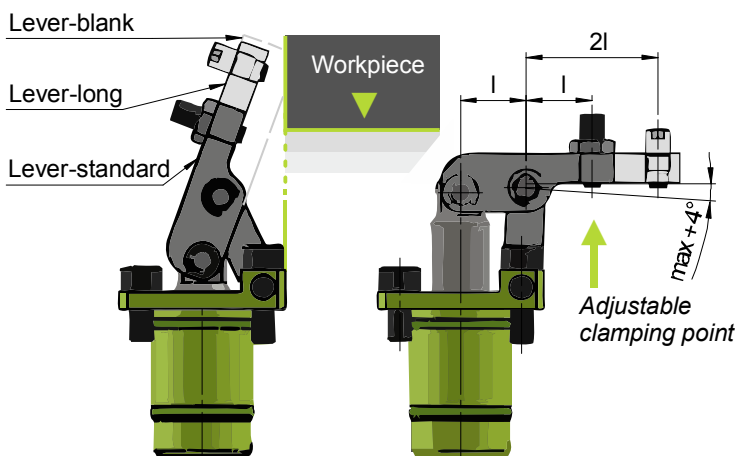

Free loading with all lever arm sizes

Lever Ratio 1:1 as Standard or 1:2 as Long-Version

Recommendations for use:

The cylinder is suitable for any installation position and allows an absolute freedom to insert the workpiece.

Even with low operating pressures, this tiny clamp generates relatively high clamping forces. It is highly important to observe the accident prevention regulations.

The specified operating pressure may not be exceeded - or only after consultation.

The adjusting screw makes it possible to adjust the clamping point in a way that the clamping lever lies in the optimum vertical position relative to the generated clamping force.

We recommend as medium- hydraulic oils according to DIN1524.

A pneumatic detection is available as option.

Description:

The small lever clamp is a double-acting push cylinder. To clamp the workpiece the clamp arm is moved along defined pivot points.

This clamp is characterized by a very good size-to-power ratio and has also an adjustable clamping point.

Likewise, this clamp allows the workpieces to be freely inserted, regardless of the clamping lever size (clamping levers made by the customer may vary from this).

Due to the metallic scraper edge and the defined guide, the clamp is largely insensitive to chips of any kind.

All clamping levers are made of heat-treated steel.

A pneumatic detection is offered as an option for reliable position detection of the clamping lever.

The securing rings of the clamping element are clearly more loss-proof than those of comparable products.

Seals and mounting screws are included in the scope of supply!

Application examples:

Right picture:
Clamping with easy pneumatic release detection.

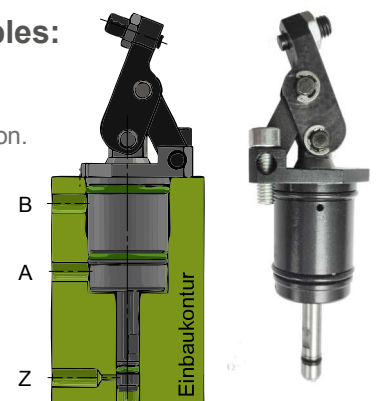

Picture below:
Clamping with Workpiece query.

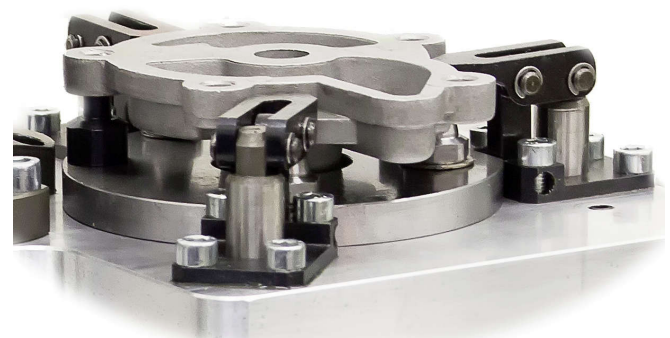

Contact

iNOSOL GmbH
Frankfurter Str. 18
35315 Homberg/Ohm (Germany)

web: www.inosol.solutions
email: info@inosol.solutions
tel.: (+49) 6633 / 368 95 25

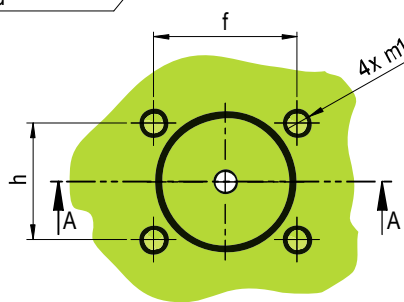
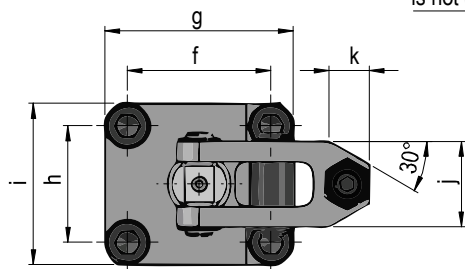
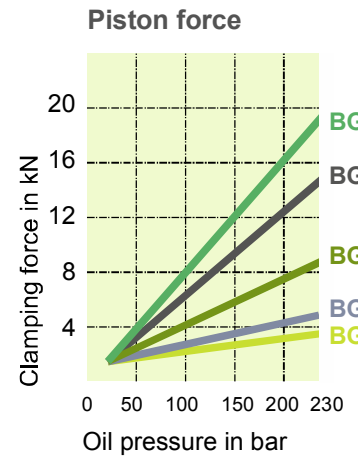
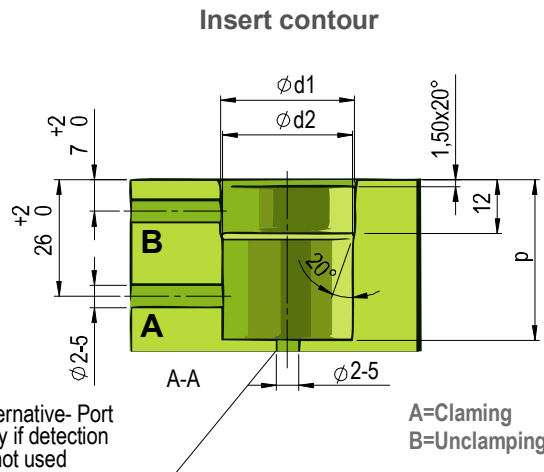
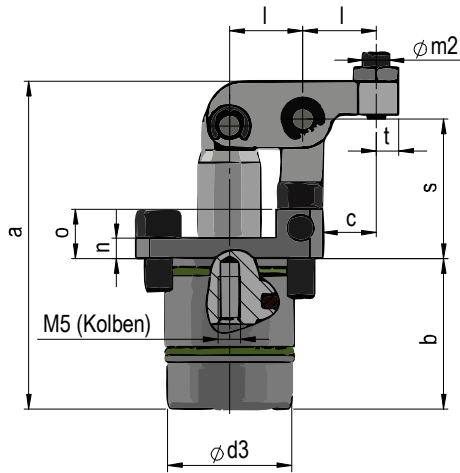

** By using the „M5“ thread in the piston, a shift rod or the - also available- pneumatic detection can be installed if required.

By making use of this possibility the effective piston area is reduced!

Technical Data

Size	Unit	1	2	3	4	5
Piston force at 200 bar	[kN]	3,08	4,02	7,60	12,31	16,08
Piston force at 100 bar	[kN]	1,54	2,01	3,80	6,15	8,04
Clamping force at 200 bar - Standard-Lever *	[kN]	3,08	4,02	7,60	12,31	16,08
Clamping force at 200 bar with Long-Lever *	[mm]	1,54	2,01	3,80	6,15	8,04
Piston-Ø **	[mm]	14	16	22	28	32
a	[mm]	54	62	74	89,5	95
b	[mm]	26,5	30	34	42	44
c	[mm]	8	10	12	14	17
d1 (+0,06)	[mm]	20	22	30	36	40
d2 (+0,06)	[mm]	19	21	29	35	39
d3	[mm]	18	20	28	34	38
e	[mm, ca.]	10	12	15	20	20
f	[mm]	23	25	32	37	42
g	[mm]	30	34	42	50	26
h	[mm]	17	18	26	32	36
i	[mm]	24	27	36	45	50
j	[mm]	12	14	19	22	25
k	[mm]	6	7,5	9	11	12
l *	[mm]	11,5	13,5	16,5	19,5	21,5
m1	[mm]	M4; 8 deep	M5; 10 deep	M6; 12 deep	M8; 16 deep	M8; 16 deep
m2	[mm]	M5	M5	M6	M8	M10
n	[mm]	3	3,5	4,5	5	5
o	[mm]	7	8	11	14	18
p min. (with pneum. Position det. see TP)	[mm]	27	30,5	34,5	42,5	44,5
s	[mm]	22	25	31,3	36	39
Part number		ITLC14-001	ITLC16-001	ITLC22-001	ITLC28-001	ITLC32-001
** = Observe the indications regarding the use of position detection!		hardened	hardened	burnished	burnished	burnished

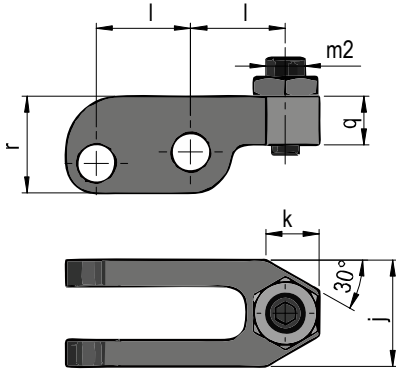

Clamping Lever - Standard



Clamping Force

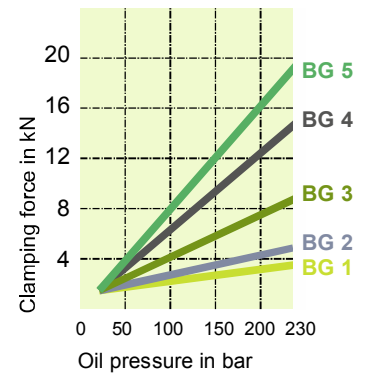

Size	Unit	1	2	3	4	5
For Part number		ITLC14-001	ITLC16-001	ITLC22-001	ITLC28-001	ITLC32-001
Clamping force at max. 230 bar	[kN]	3,54	4,62	8,74	14,16	18,49
l	[mm]	11,5	13,5	16,5	19,5	21,5
j	[mm]	12	14	19	22	25
r	[mm]	7	8	10	13	15
s	[mm]	7	8	9	12	13
u	[mm]	31	35,5	43	52,5	61,5
k	[mm]	6	7,5	9	11	12
m2	[mm]	M5	M5	M6	M8	M10
Part number		ITLC14L-001	ITLC16L-001	ITLC22L-001	ITLC28L-001	ITLC32L-001

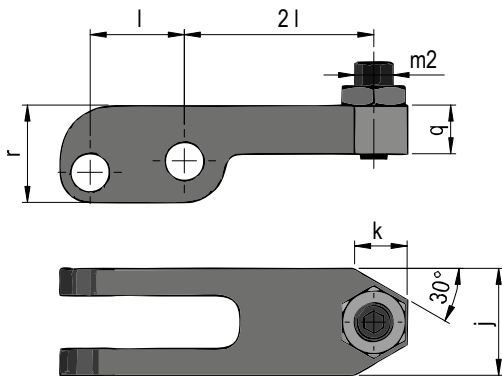

Clamping Lever - Long

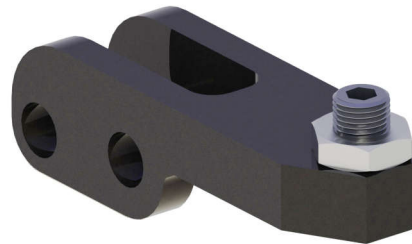

Clamping Force

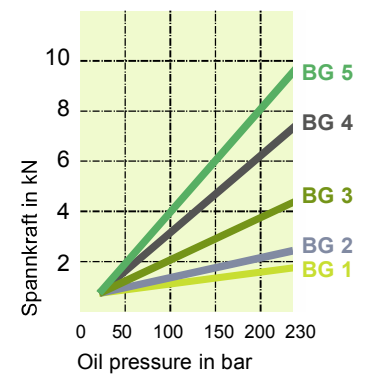

Size	Unit	1	2	3	4	5
For Part number		ITLC14-001	ITLC16-001	ITLC22-001	ITLC28-001	ITLC32-001
Clamping Force at max. 230 bar	[kN]	1,77	2,31	4,37	7,08	9,245
l	[mm]	11,5	13,5	16,5	19,5	21,5
j	[mm]	12	14	19	22	25
r	[mm]	7	8	10	13	15
s	[mm]	7	8	9	12	13
u	[mm]	31	35,5	43	52,5	61,5
k	[mm]	6	7,5	9	11	12
m2	[mm]	M5	M5	M6	M8	M10
Part number		ITLC14L-001	ITLC16L-001	ITLC22L-001	ITLC28L-001	ITLC32L-001

Contact

iNOSOL GmbH
 Frankfurter Str. 18
 35315 Homberg/Ohm (Germany)

web: www.inosol.solutions
 email: info@inosol.solutions
 tel.: (+49) 6633 / 368 95 25

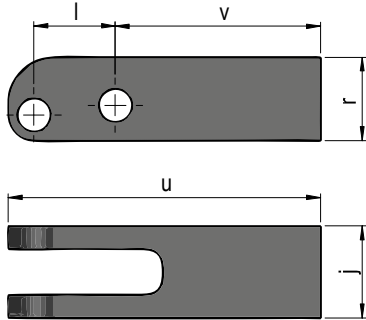

Clamping lever - semifinished

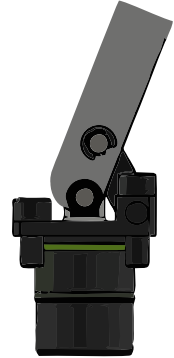

Size	Unit	1	2	3	4	5
For Part number		ITLC14-001	ITLC16-001	ITLC22-001	ITLC28-001	ITLC32-001
l	[mm]	11,5	13,5	16,5	19,5	21,5
j	[mm]	12	14	19	22	25
r	[mm]	7	8	10	13	15
u	[mm]	45	50	61	75	84
v	[mm]	30	33	40	50	55
Part number		2012005	2014005	2019005	2022005	2025005

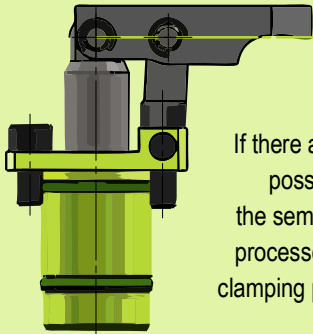

Hint

If there are any concerns regarding possibly occurring lateral forces, the semifinished clamp arm can be processed, so that the pivoting and clamping point are on the same level as shown here.

Calculation - Clamping Force

Clamping force depending on the operating pressure when using the long lever.

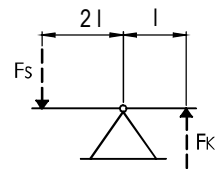

$$\text{Clamping Force } F_s = \frac{F_k \times l}{2l}$$

F_s = Clamping force
 F_k = Piston force
 l = Length betw. clamping point and pivoting point

➔ General notes

We do not recommend the operating situation shown below!

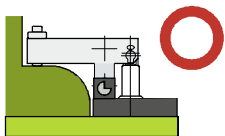

Clamp arm too long

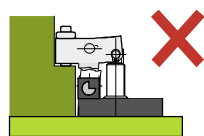

Clamp arm too short

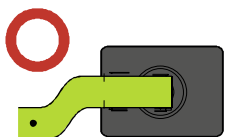

Cranked clamp arm

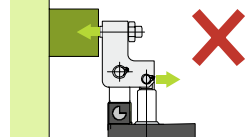

Angled clamp arm

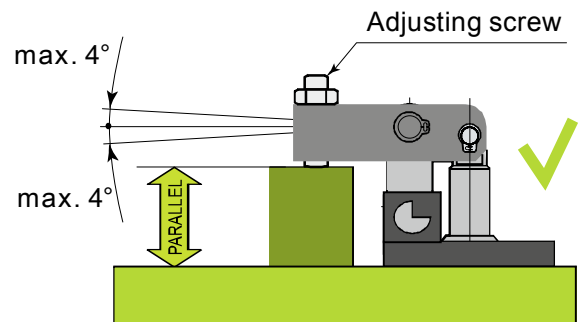

Contact

iNOSOL GmbH
 Frankfurter Str. 18
 35315 Homberg/Ohm (Germany)

web: www.inosol.solutions
 email: info@inosol.solutions
 tel.: (+49) 6633 / 368 95 25

 **Pneumatic detection**

Insert contour

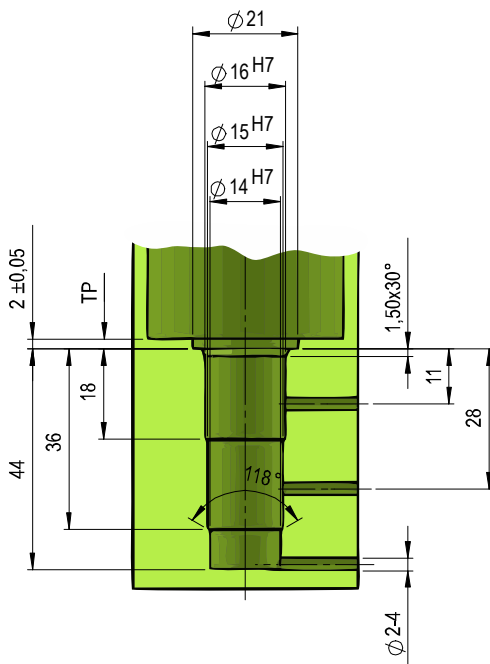

Function

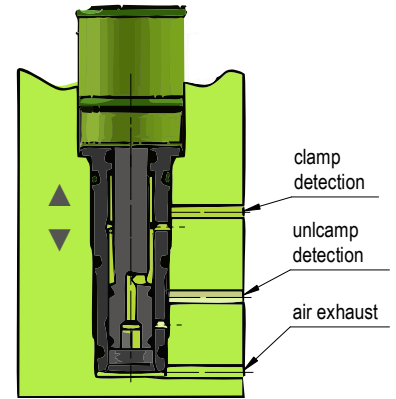
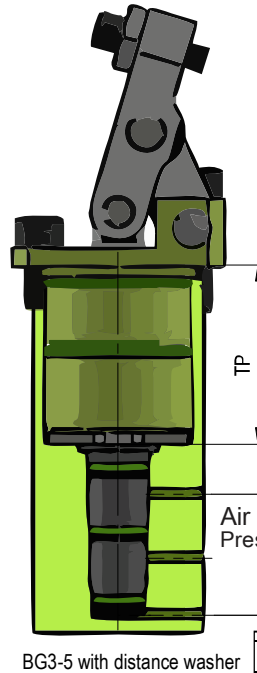

BG 2 without distance washer

Sample: Clamping detection

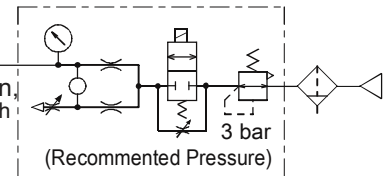

Part number- pneumatic detection	For size...	TP (+/- 0,05)	Effective area (mm ²)	Piston Thread	Piston-Ø
ITLC16-P02	2	-	163	M5	16
ITLC22-P02	3	35,50	238	M5	22
ITLC28-P02	4	44,00	313	M5	28
ITLC32-P02	5	47,00	364	M5	32

Note:

No clamping errors are detected. By this method only the two end positions are determined.

No query option is available for size 1 (BG1).

 **Product-Examples**

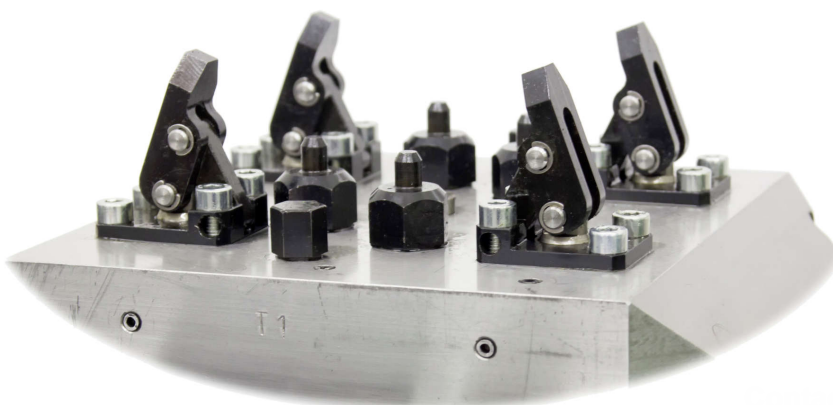

Examples with special clamping levers



Die Baugrößen 1-2 sind mit gehärtetem Gehäuse ausgeführt.

Contact

iNOSOL GmbH
Frankfurter Str. 18
35315 Homberg/Ohm (Germany)

web: www.inosol.solutions
email: info@inosol.solutions
tel.: (+49) 6633 / 368 95 25