

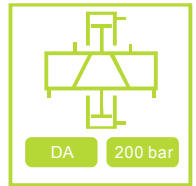

Advantages:

- ✓ Flat design with high forces
- ✓ High repeatability
- ✓ Identical force when opening and closing
- ✓ Incl. pneumatic workpiece and end position detection *
- ✓ Can be used as a centering vise or clamping vise
- ✓ No overhanging components
- ✓ Also suitable for insert installation



Generally

Description:

The protected operating principle(©) of this two-jaw centering clamp enables a very flat and compact design. With this clamping vise both, external and internal centering of the workpieces to be clamped is possible, with identical forces.

This clamping element can also be equipped with only one movable jaw, which allows clamping against a fixed stop.

The complete or partial insertion of this clamping element in a lowered contour is also possible, since no components protrude beyond its base. The sliding parts (jaws) can be lubricated directly (manually) as well as centrally (automated) if required.

Pneumatic query channels are also integrated, with which the outer and inner end positions of the jaws can be detected. In addition, the integrated pneumatic component query can be used with customer jaws, which often makes additional queries and supports unnecessary.

Furthermore, this element is independent of the installation position and all connections are at the bottom.

It can also be used as a hydraulic gripping- or positioning element. Pneumatic solution on request.

*The possibility of pneumatic query relates to the channels prepared for this.

Recommendations for use:

This element can be used both as a hydraulic centering / parallel clamp, which makes it suitable for integration into a clamping device as well as a "stand-alone" solution for clamping components in a 5-axis machining center. This element can also be used for gripping and positioning due to its compactness. The centering clamp can also be operated with an adapter plate by using the thread connections, which is also available. In this case, however, the possibility of using the pneumatic detections is eliminated.

This element can be used universally, especially in automated processes, because the query/detection options described are integrated. Due to the use of individually manufactured centering and clamping jaws, with the very compact dimensions, combined with the high clamping forces, this element offers a very wide range of possible applications.

Key data

Size	Unit	IFCC30	IFCC40	IFCC50
Clamping frc. @ 150 bar	[kN]	5,2	8,3	12,5
Min. working pressure	[bar]	30	30	30
Max. temperature	[°C]	80	80	80
Overall height, complete	[mm]	30	40	50
Repeatability	[mm]	+/-0,02	+/-0,02	+/-0,03

Example applications

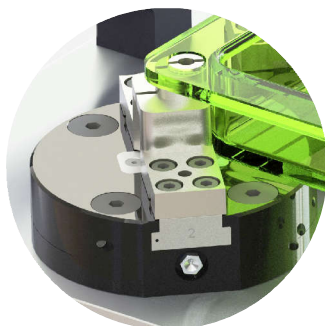

Integration into a clamping fixture with Bore Hole Clamping



Integration in a multiple clamping fixture with Outside clamping

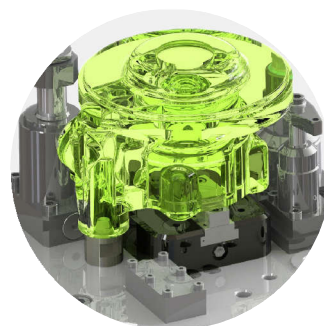

Integration into a clamping fixture with Inside Clamping



Use as Positioning or Gripping Element

Dimensions

Rectangular design

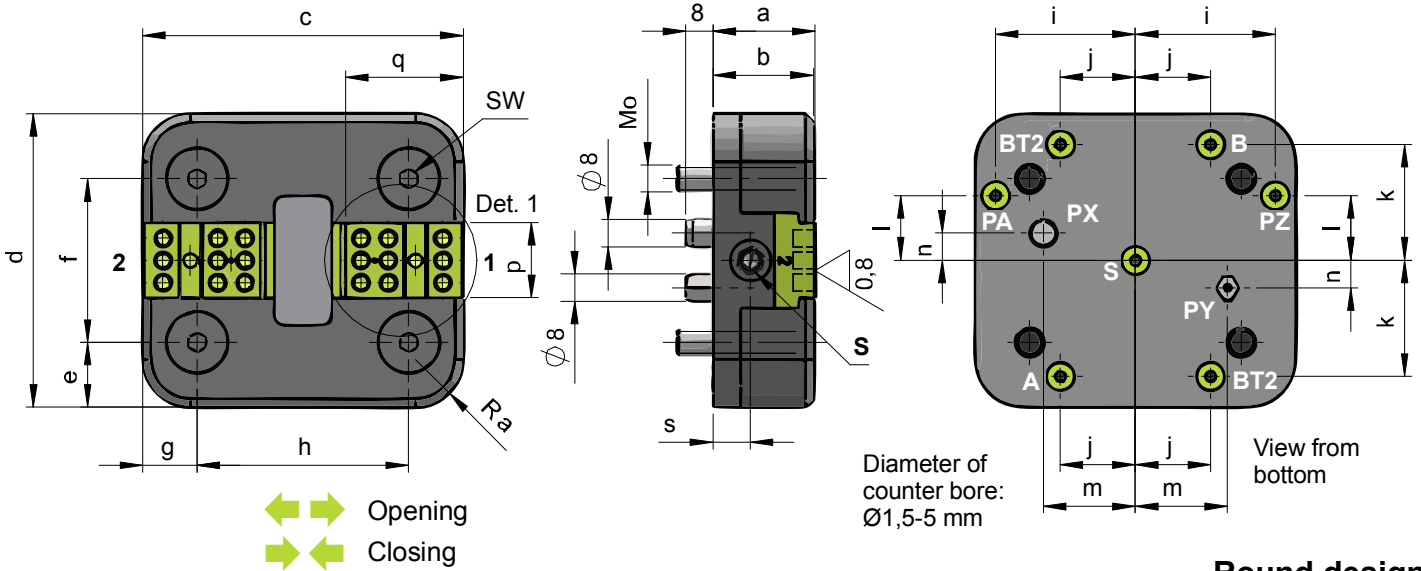

Round design

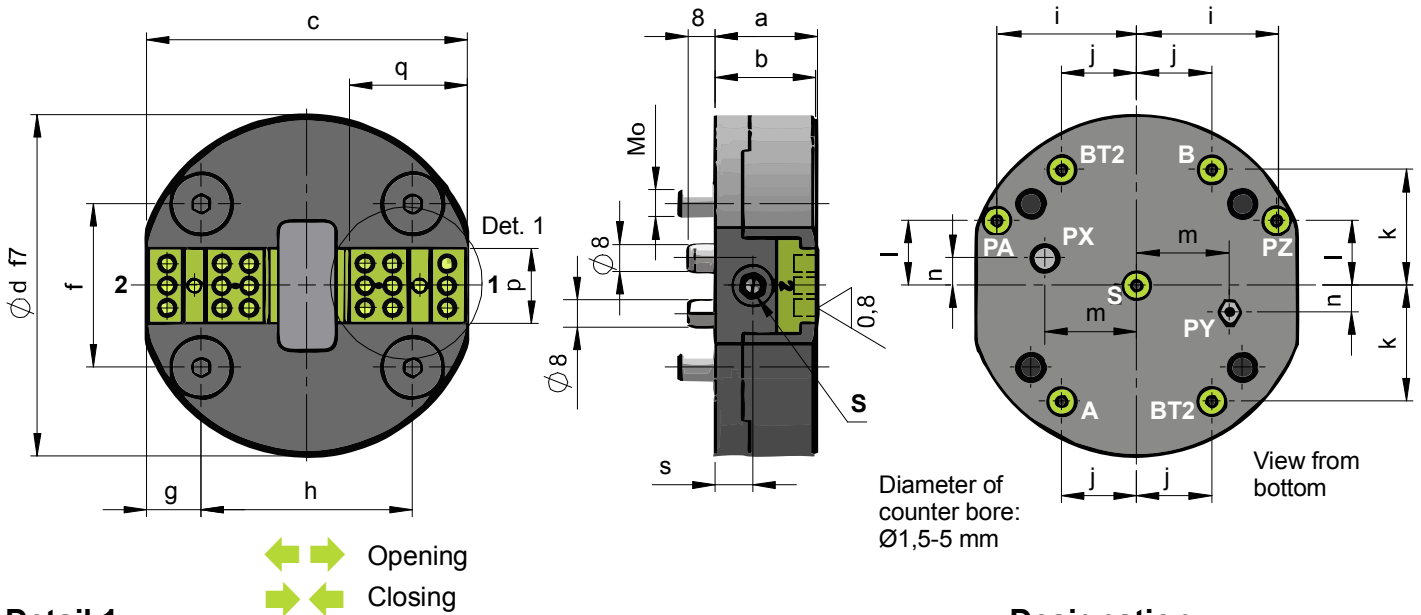

Detail 1

Designation

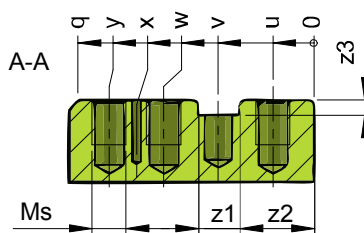
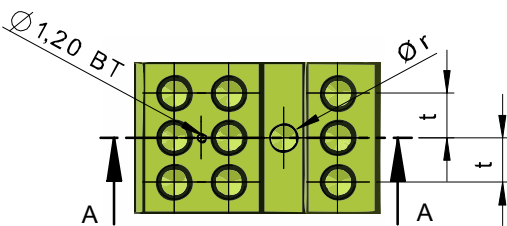

- A = Closing
- B = Opening
- PA = Query - jaws open
- PZ = Query - jaws closed
- BT1= Workpiece detection 1
- BT2= Workpiece detection 2
- PX = Centering pin
- PY = Positioning pin
- S = Lubrication connection

Notes!

- The **open position** of the jaws is always shown.
- In the version with a **fixed jaw**, this is always **jaw 1**, in the open position.

The queries PA, PB, BT1, BT2 are related to the intended pneumatic channels.

PX is a round pin.
PY is a chamfered pin.

Technical data

Dimensions and part numbers

Size	Unit	30	40	50
Force at 200 bar hydraulic	[kN]	7,60	12,50	16,80
Force at 100 bar hydraulic	[kN]	3,20	5,20	8,30
clamping stroke per jaw	[mm]	2,50	2,70	3,50
a (Height: lower edge to upper edge sliders)	[mm]	30 +/-0,015	40 +/-0,020	50 +/-0,022
b (housing height)	[mm]	29,5	39,5	49
c	[mm]	94	124	148
d (Rectangular design / round design)	[mm]	86 / 100	114 / 135	148 / 160
e	[mm]	18	24	28,5
f	[mm]	48	66	79
g	[mm]	12	15	24
h	[mm]	62	84	100
i	[mm]	41	56	67
j	[mm]	22	26	32
k	[mm]	34	47	56
l	[mm]	19	27	30
m	[mm]	27	42	54
n	[mm]	8	12	18
Mo (Screw DIN7991 x length)	[mm]	M8x40	M10x50	M12x70
Ms (Thread x screw in depth)	[mm]	M5x7	M6x12	M8x16
p	[mm]	22	30	35
q	[mm]	34,5	46	53
Ra	[mm]	14	18	22
u	[mm]	6	7	10
v	[mm]	14	19	23
w	[mm]	22	31	36
x	[mm]	26	35,5	41,5
y	[mm]	30	40	47
z1 (+0,02)	[mm]	6	8	10
z2	[mm]	11	15	18
z3	[mm]	2,2	2,6	3,2
Ør (H7)	[mm]	4	5	6
SW	[mm]	5	6	8
s	[mm]	11	13,5	17
t	[mm]	6,5	10	11,5
Weight (Rectangular / Round)	[kg]	1,80 / 1,74	4,05 / 3,95	7,2 / 7,1
Part number				
Rectangular centering vise, hydraulic		IFCC30-001	IFCC40-001	IFCC50-001
Rectangular centering vise, jaw 1 - fixed jaw, hydr.		IFCC30-002	IFCC40-002	IFCC50-002
Round centering vise, hydraulic		IFCC30-003	IFCC40-003	IFCC50-003
Round centering vise, jaw 1 - fixed jaw, hydraulic		IFCC30-004	IFCC40-004	IFCC50-004

Clamping force

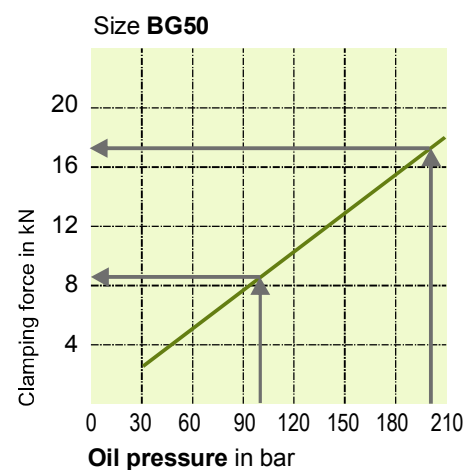
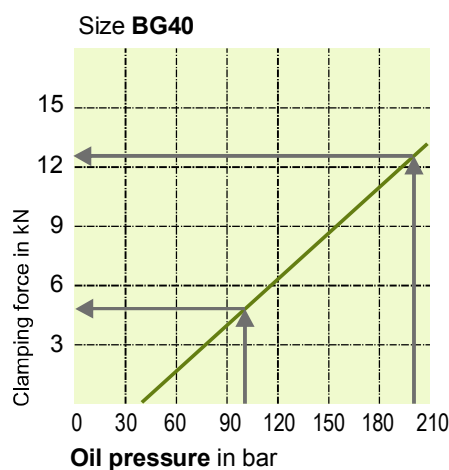
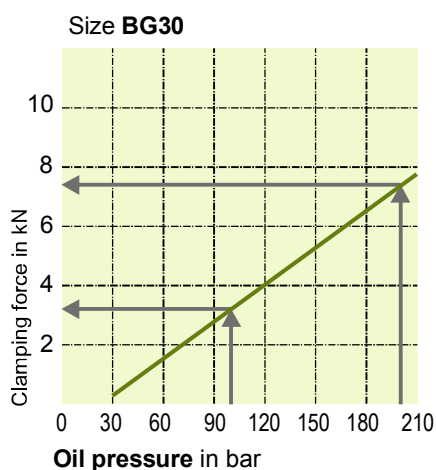

Adapter plate

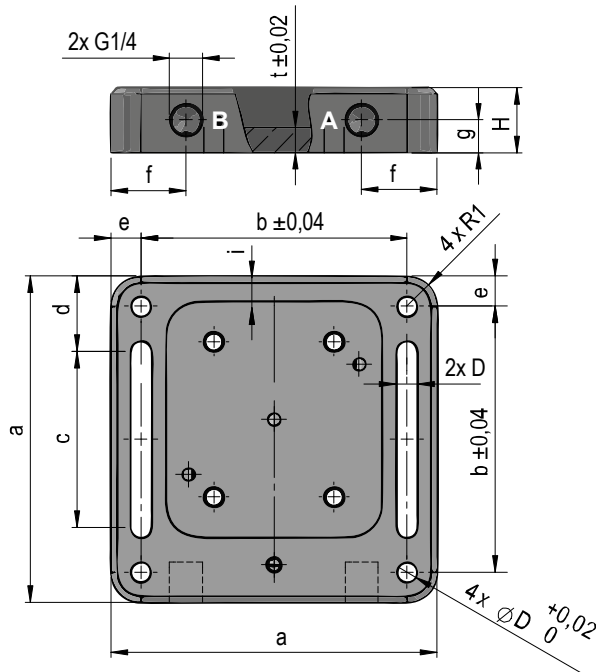

For the adapter plate the use of queries is not provided!

The adapter plate is used for operation

- by means of the **threaded connections** for pressure supply
- and for **direct mounting** on a processing table



The outer 4 holes can be used for fixing or for positioning with using dowel pins.

Size	Unit	IFCC30	IFCC40	IFCC50
a	[mm]	130	168	195
b	[mm]	106	140	163
c	[mm]	70	96	112
d	[mm]	30	35	40
e	[mm]	12	14	16
f	[mm]	30	36	42
g	[mm]	13	15	16
H	[mm]	26	30	35
t	[mm]	10	12	12
D	[mm]	8	10	12
R1	[mm]	12	15	16

Part number IFCC30-AP1 IFCC40-AP1 IFCC50-AP1

Connecting example

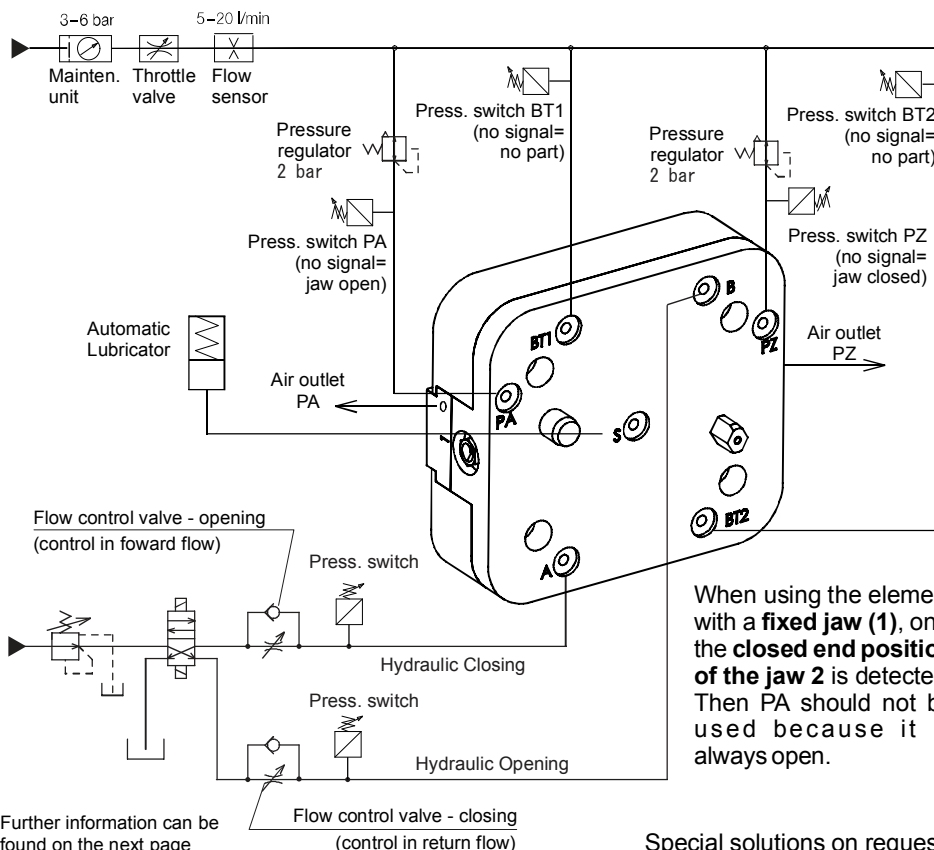

- A** = Closing
- B** = Opening
- PA** = Query - Jaws open
- PZ** = Query - Jaws closed
- BT1** = Workpiece detection 1
- BT2** = Workpiece detection 2

This scheme is only an example. The assignment and use of the connections must be selected according to individual requirements.

BT1 and BT2 can also be combined or only one of the two channels can be used.

In many cases, it is also sufficient to detect only one of the jaw positions. This can be PA (open) or PZ (closed).

It should be noted here that the switch does **not give a signal** when the respective **end position has been reached**.

If this position is not reached, the switch gives a signal.

The required volume flow of the compressed air depends on the number of queries used and must be determined by calculation or in practice.

The pressure switches and the flow control valves in the hydraulic circuit are also optional.

When using the element with a **fixed jaw (1)**, only the **closed end position of the jaw 2** is detected. Then PA should not be used because it is always open.

Special solutions on request!

Further information can be found on the next page under Design Notes.

Design Notes

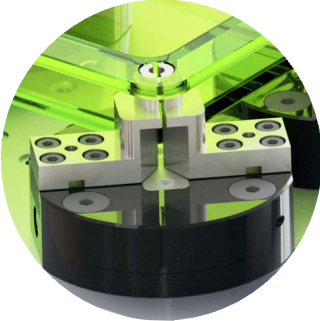

To ensure correct opening and closing of the clamping jaws, under cuts must be provided on the adjacent components in all movement direction of the clamping jaws. This is particularly necessary if flushing or blowing away of chips that may occur is not possible, or only to a limited extent.

For optimal positioning and force absorption, the custom-made clamping jaws must use the positioning hole and the groove by means of form-fitting connections. Dowel pins and/or parallel keys should be used for this.

The pressure switches and flow control valves in the hydraulic circuit are only limited required. The centering element can handle very small as well as large volume flows. The **volume flow should be between 2-9 l/min**. Due to the self-locking, the clamping element keeps the clamping force even if the pressure drops.



If the centering and/or positioning pin on the underside is not required, they can be removed or there can be bores in the installation contour that are approx. 1mm larger.

Regardless of the direction in which clamping/centering is used, the actual tensioning point should be approximately in the middle of the overall stroke.

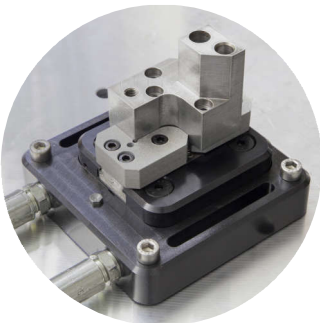

The workpiece detection can be used for clamping query.

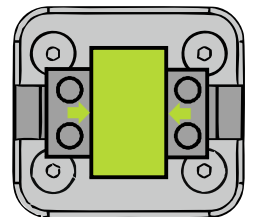
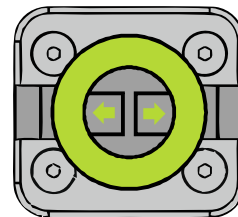
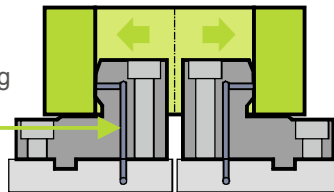

If the centering clamping element is used as a vise, the external possibility for lubrication of the adapter plate can be used.

The width of the jaws should not exceed the factor 2 of dimension "p" from the sheet.

Clamping jaws are only available on request.

Recommendations

1 The centering clamp can be used flexibly for clamping in holes with small material thickness and very close to the workpiece edge.

2 This element can also be used as a central clamping element, combined with other elements, whereby always the pneumatic queries can be used.

3 The compact and flat design enables the integration of the element in a clamping device, so space saving, that in a multiple clamping fixture the complete machining is quite possible.

4 The use as a parallel gripper, centering and positioning element is also possible because, regardless of whether inside or outside centering, always the same forces are generated.

