



Principle 3

Principle 2

Principle 1

Advantages:

- ✓ Suitable for high pressure
- ✓ No lock nut is required
- ✓ Suitable for high temperatures
- ✓ 3 different principles
- ✓ Applicable for different media



Principle 1

Due to the simple design, the vent plugs are very insensitive to external influences.

For venting only one Allen key WS3 is required.

The inner vent screw is to open in counterclockwise sense.

Because of that, there is no risk of loosening of the outer screw while closing.

It is sufficient to open the inner screw only a half turn for venting.

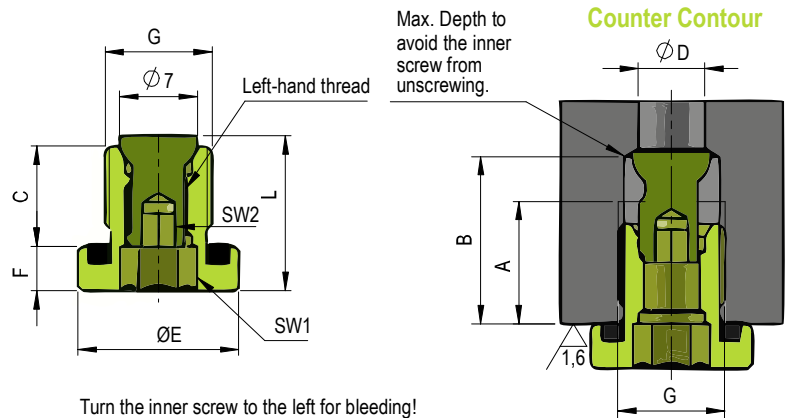

p/n	Principle	G	L	A	B	C	D	E	F	SW1	SW2
IVS-002	1	G1/4	19,5	13,00	14-17	12	1-6	19	5	6	3
IVS-007	1	G1/8	14	11,00	12-15	9	1-6	14,5	4	6	3
IVS-019	1	M10x1	14	11,00	12-15	9	1-6	14,5	4	6	3

Principle 2

At the end of the screw there is a hose nozzle integrated to connect a PVC-Tubein Size 8.

For venting an open-end wrench can be used. The hose nozzle can be used to flush the piping system.

The screw is designed to seal against a 60-120° drilling.

p/n	Principle	G	L	A	B	C	D	E	F	SW1	Accessory
IVS-001	2	M8	31,5	8,00	10,5-13,5	ca. 17,5	2-3,5	9,5	ca. 18	9	7100032 IVS-C-003
IVS-006	2	G1/8	33	9,00	11,5-13,5	ca. 18	3,5-6,5	9,5	ca. 17,5	10	7100032 IVS-C-003
IVS-029	2	M6	31,5	9,00	10,5-13,5	ca. 16,5	2-3,5	11	ca. 17	9	7100032 IVS-C-003

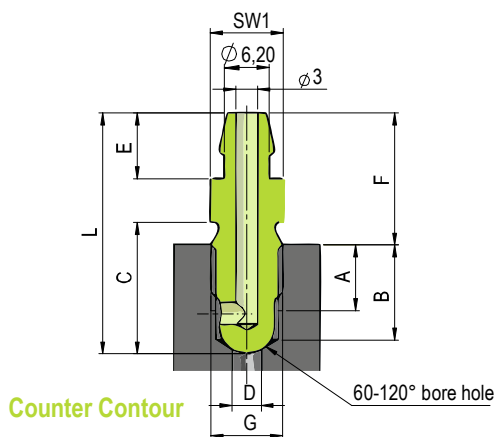

Protection cap from 316L as Accessory

Part number: IVS-C-003



Protection cap from Vinyl as Accessory

Part number: 7100032

Contact

INOSOL GmbH
Frankfurter Str. 18
35315 Homberg/Ohm (Germany)

web: www.inosol.solutions
email: info@inosol.solutions
tel.: (+49) 6633 / 368 95 25

Principle 3

This vent screw can be screwed into any counter contour.
It is not necessary to produce the sealing contour for the metallic sealed inner screw here.

The inner vent screw is opened counter-clockwise.

It is sufficient to open the inner screw half a turn to bleed air.

A hose nozzle is integrated at the end of the screw, onto a PVC hose size. 8 can be attached.

Venting/bleeding can take place using an open-end wrench, and the hose connection can also be used to rinse/clean the pipe system.

p/n	Principle	G	L	A	E	SW1	SW2
IVS-022	3	G1/8	42	9,0	18	9	17
IVS-023	3	G1/4	43	10,0	18	9	19
IVS-028	3	M12x1	34	8,0	17	8	15

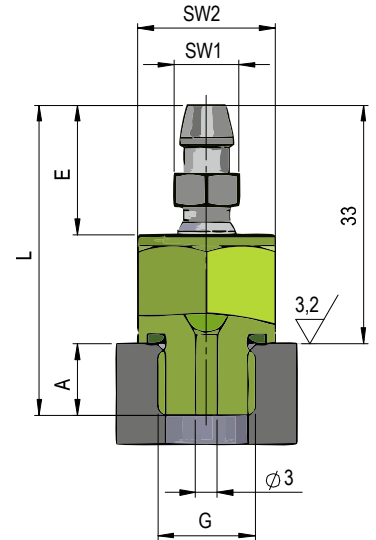

Generally

Bleeding the hydraulic:

Air inclusions can cause a diesel effect, especially at high pressures or pressure fluctuations. This effect contributes to oil aging and increased temperatures. Which subsequently leads to seal wear.

An additional negative effect is that air diffuses through the sealing material in the direction of the low-pressure side. The pressure drops so steeply on the surface of the seal that the air bubbles expand suddenly and damage the seal. Depending on the extent of such "micro-explosions", the surfaces of the sealing and running surfaces can also be damaged very quickly in such a way that they look like they are exposed to abrasive wear. Compressed air inclusions can destroy the sealing and guiding surface when this air is passing over.

Venting in difficult places:

With the protected principle 1 it is possible, to vent the system at difficult reach locations. Furthermore this solution can be used as a replacement of standard closing screws.

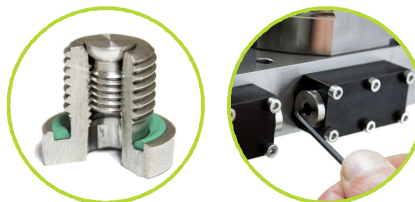

Clean venting and flushing:

With principles 2 and 3, it is possible to connect a compressed air hose of size 8 and to carry out a targeted discharge of the medium or a flushing of the pipe system. In principle 1, a size 6 compressed air hose can be plugged in.

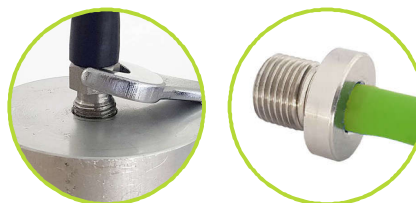

Note:

All information relates exclusively to the use in connection with iron and steel materials.

The components are only intended to be used accordingly. That means, for bleeding the oil hydraulics.

Generell Data

Max. working pressure:	400 bar
Max. temperature:	200°C
Material:	S316 / 316L
Sealing material:	FKM

Torque	Inner screw	Outer screw
IVS-001 (Nm)		7-9
IVS-002 (Nm)	4-7	26-28
IVS-006 (Nm)		10-16
IVS-007 (Nm)	4-7	18-22
IVS-019 (Nm)	4-7	18-22
IVS-022 (Nm)	7-9	18-22
IVS-023 (Nm)	7-9	26-28
IVS-028 (Nm)	5-6	24-25
IVS-029 (Nm)		5-6

Contact

iNOSOL GmbH
Frankfurter Str. 18
35315 Homberg/Ohm (Germany)

web: www.inosol.solutions
email: info@inosol.solutions
tel.: (+49) 6633 / 368 95 25